

## Ferrites for High Frequency Noise Suppression Chapter 9

### Introduction

The drive for higher speed devices and the proliferation of widespread consumer electronics has resulted in increasing problems associated with circuit interoperability and signal suppression concerns. In the commercial electronics industry, government agencies throughout the world have implemented extensive regulations limiting unwanted radio frequency interference (RFI) that can be generated by modern electronic equipment. Ferrites, because of their unique magnetic characteristics and their ease of application after the fact have been and are being used increasingly to suppress unwanted signals emanating from electronic components and circuits. This signal suppression capability is also useful in decoupling high frequency circuits and in reducing parasitics in fast switching devices.

### Shield Beads

Ferrite beads, also called shield beads, with or without a shunting capacitor, are universally accepted as a popular and standard fix in circuit noise suppression schemes. Ferrites, however, hold the loan position as the device easiest to install without effecting normal circuit operation in the D.C. and low frequency range, or as is often the case, without changing or altering the existing circuit board.

Ferrites are usually a small cylinder or a flat washer which is simply slipped over the component leads, around the wire bundle, around the line carrying the unwanted signal, or under the of fending IC. A single bead is shown in Figure 9-1, while Figure 9-2 shows a ferrite wafer under an IC. Sometimes the ferrite material is built into to device itself. Figure 9-3 shows the application of ferrite material around the conducting pin inside a shielded pin filtered connector.

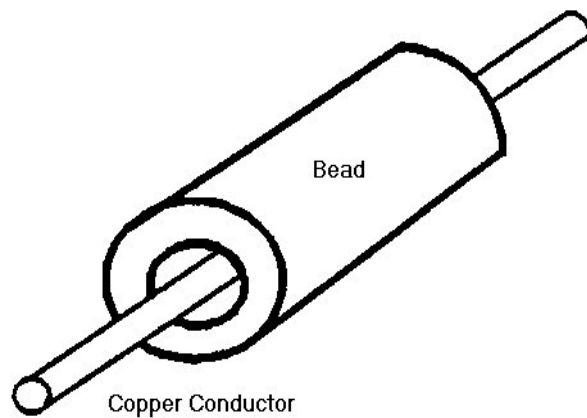

Figure 9-1 Single Ferrite Bead on Wire

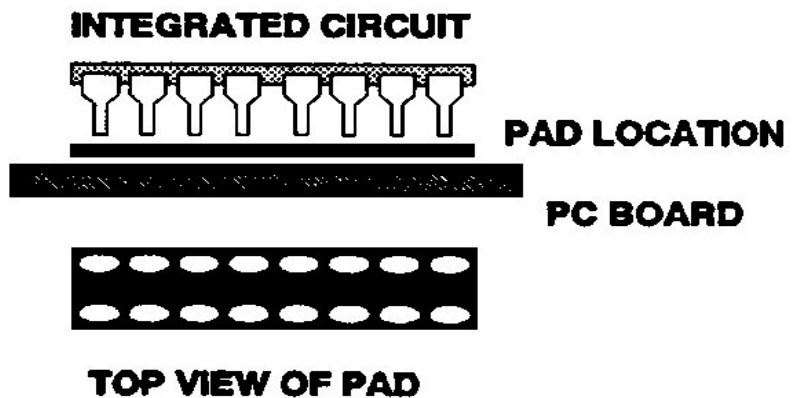

Figure 9-2 Ferrite Pad Used for IC

The bead introduces a small inductance to low frequency current, increasing with frequency through a sharp reduction in magnetic permeability. Simultaneously, the magnetic losses increase such that the unit behaves like a resistor in the circuit at higher frequencies.

Effectively, the device is converting the high frequency signal energy to heat through magnetic losses, while at DC and low frequency there is little or no effect. Figure 9-4 shows typical insertion losses for two sizes of a ferrite tube Low-pass filter. Figure 9-5 shows the impedance variations with frequency of ferrite material.

### Bead Applications

Several means are available to increase insertion impedance if the attenuation of a single bead is insufficient. The usual method is to insert multiple beads in series, creating the same effect as additional series resistors. Cores of different materials can also be mounted on the same leads to broaden the effective attenuation across a larger frequency spectrum.

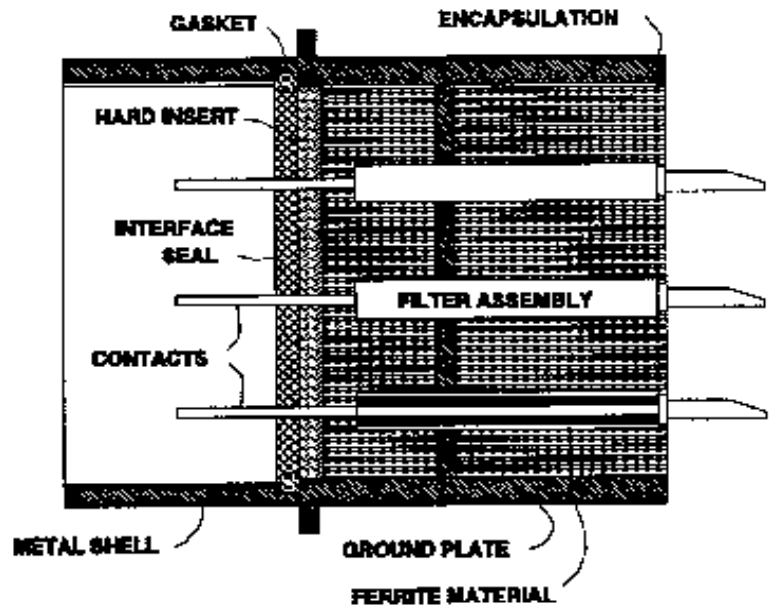

Figure 9-3 Shielded Pin Filtered Connector

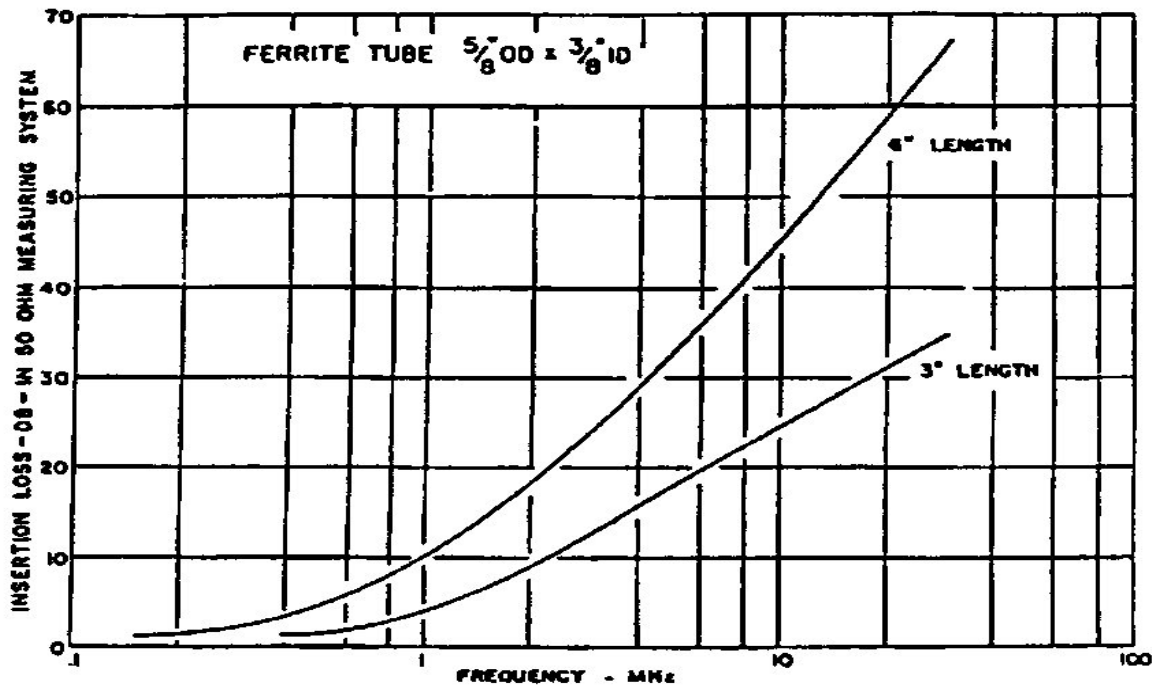

Figure 9-4 Insertion Loss of Two Sizes of Ferrite Tube Low Pass Filters

Still larger impedances can be obtained by using multi-hole cores, as shown in Figure 6, with a single lead looped through each hole. However, as shown in Figure 7, increasing the number of loops in a single core soon reaches a point of diminishing returns. Two and one-half turn loop seems to be the optimum for most applications. While two hole, four hole, and six hole cores are available from manufacturers, the six hole version is usually supplied as a wound choke.

If additional attenuation is necessary after using multiple turns, connecting a small capacitor across the load, between the ferrite choke and the load, will provide the maximum attenuation available from this technique.

The impedance of the a ferrite filter (Figure 9-8) can be calculated as shown below. This combination provides a damping factor or equal to the bead impedance multiplied by the reactance of the capacitor. The condition also introduces resonant peaks in the value of impedance at certain frequencies depending on reactance.

In Figure 9-8,  $Z_{SB}$  is equal to:

$$|Z_{SB}| = \sqrt{R_s^2 + X_s^2}$$

In addition to their use with a capacitor, ferrites also find widespread usage to control the high frequency effects of regular LC filters.

As shown in Figure 9-9, standard commercial low-pass filters loose their effectiveness when their wire wound inductors become capacitive and their capacitors become inductive due to lead length. Inserting a lossy ferrite bead in the filter will absorb excess energy at frequencies where the filter characteristics change.

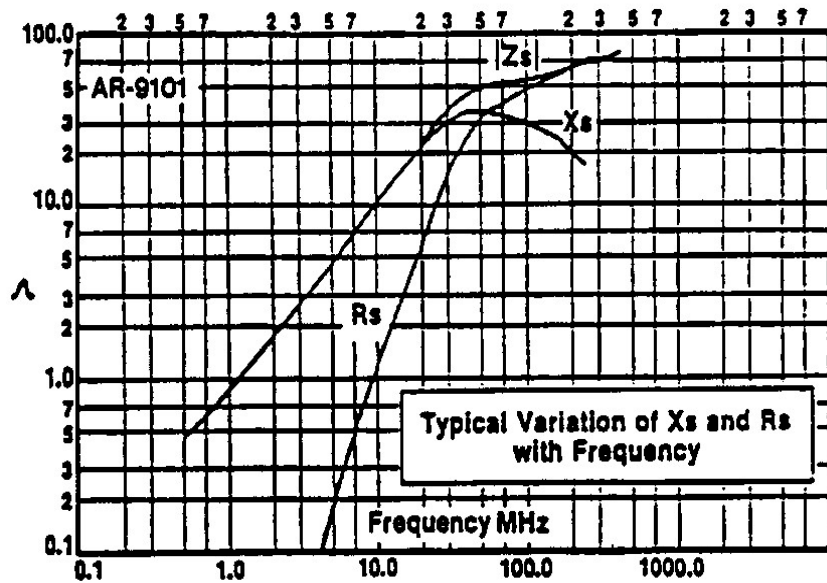

Figure 9-5 Impedance Variation With Frequency of Ferrite Material

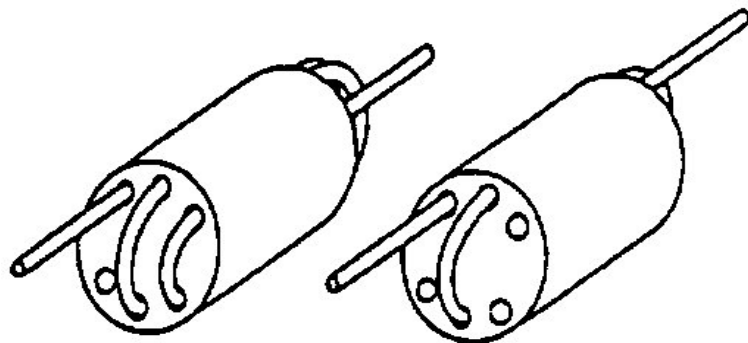

Figure 9-6 Multi-Hole Core

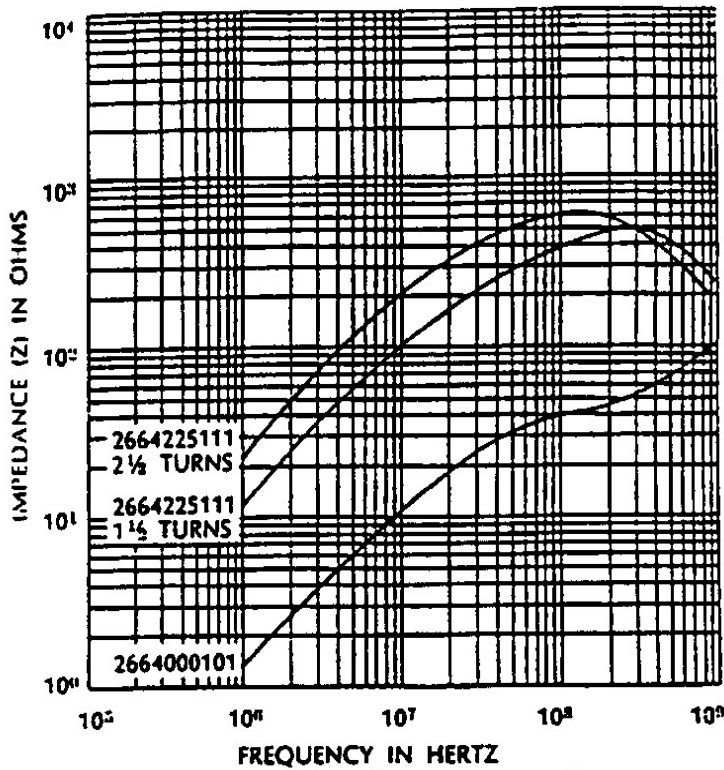

Figure 9-7 Decreasing Bead Impedance With Multiple Turns

By substituting current and impedances for voltage, the network equations can be solved as shown below to determine the final insertion loss equation.

$$E_A = I_A Z_A = \frac{E_I}{Z_G + Z_L} Z_L$$

$$E_B = I_B Z_L = \frac{E_I}{Z_G + Z_{SB} + Z_L} Z_L$$

$$A = 20 \log_{10} \frac{E_A}{E_B} = 20 \log_{10} \frac{\frac{E_I Z_L}{Z_G + Z_L}}{\frac{E_I Z_L}{Z_G + Z_{SB} + Z_L}}$$

Attenuation (A) of the signal or Insertion Loss (IL) introduced in a circuit by a ferrite bead is measured by reading the voltage across the load with and without the ferrite.

The resulting (A) is calculated from the equivalent circuits of Figure 10 as follows:

$$Attn.(A) = 20 \log_{10} \frac{E_A}{E_B}$$

where:  $E_A$  = voltage across the load without a shield bead in the circuit

$E_B$  = voltage across the load with a shield bead in the circuit.

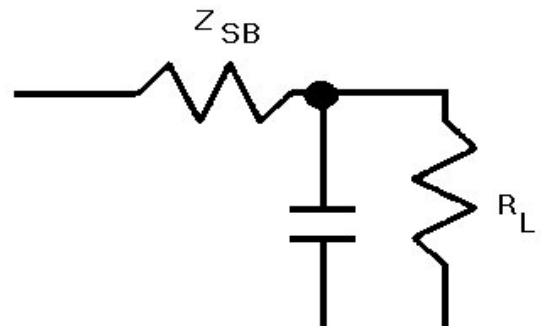

Figure 9-8 Bead & Cap Filter

$$A = 20 \log \frac{Z_G + Z_{SB} + Z_L}{Z_G + Z_L}$$

where

- $Z_G$  = the source impedance
- $Z_L$  = the load impedance
- $Z_{SB}$  = the shield bead impedance
- $E_I$  = the source voltage
- $I_A$  = current without the shield bead
- $A$  = current with the shield bead

Notice from the above equation that shield bead impedance is determined by load plus generator impedance values. Figure 9-11, from the Fair-rite Products Corporation Engineering Bulletin shows shield bead impedances for several load plus generator values.

One advantage ferrite beads have over other attenuation techniques is their ease of application to common mode noise problems. Larger beads can be mounted over the entire cable near the 1/0 driving end to effectively attenuate both high and return side noise. Toroids are also used for common mode noise, usually employing multiple turns. High signal currents in the leads are not a limitation since the magnetic fields in Normal Mode cancel if the pairs are wound bifilar. When line current such as can be found in power cords is high, high permeability toroids are required to increase the coupling between the leads for effective cancellation of the power fields.

### Toroidal Cores

Toroidal cores are another widespread use for ferrite material. Inductors designed using pot cores are usually identified as linear magnetic components *due* to their operation within the range of negligible change of effective permeability with excitation.

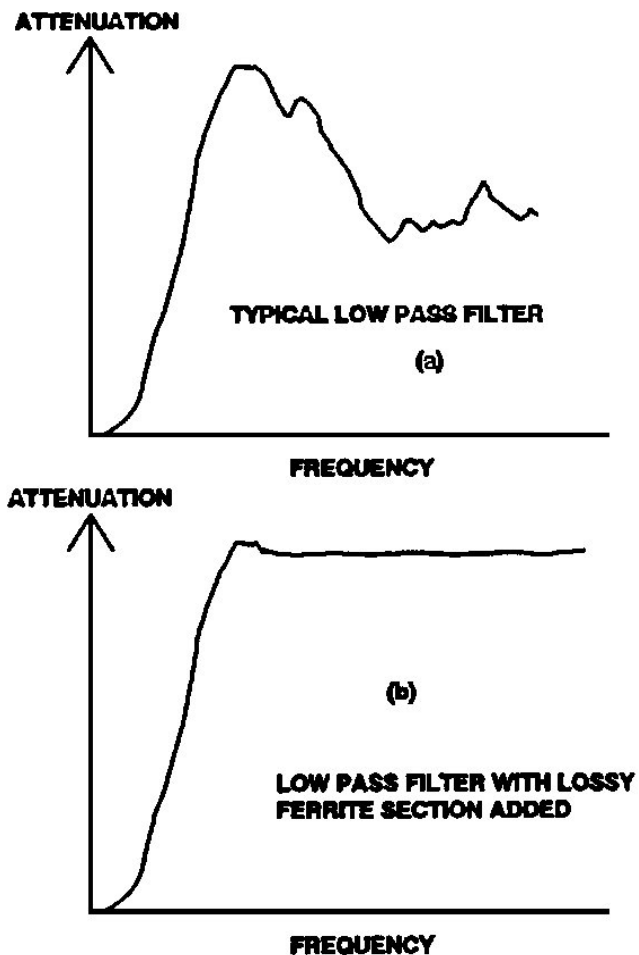

Figure 9-9 Typical Low Pass Characteristics

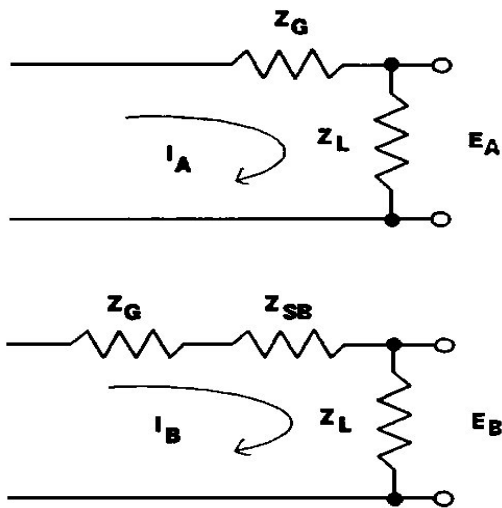

Figure 9-10 Circuit With & Without Bead

As shown in Figure 9-12, the air surrounding an air core inductor is part of the magnetic-flux path, which tends to radiate the impinging rf signals conducted to the inductor on its connecting wires. The application of a toroid completely contains the lower frequency magnetic flux within the core. Since there is less ac resistance, inductor Q can be increased dramatically, reducing the number of windings needed by the inductor.

Fine to coarse tuning of the ferrite pot core is easily accomplished by simply moving a threaded core in or out of the centerpost. Air gaps between the mating surfaces of the centerposts also provide good temperature stability.

From a TEMPEST perspective, increasing Q in an inductor is not always desirable. Increased Q provides increased impedance to conducted signals, which in turn may reflect and propagate into the air. Therefore, when using toroidal inductors, capacitive bypassing should be increased on each side of the toroid to dampen reflected signals and reduce the resultant radiated E field.

### Design Procedures for LC Circuits and RP Inductors

Since ferrites are ceramic materials with high resistivities, eddy current losses are extremely low over the applicable frequency range. Hysteresis losses can be kept low with proper selection of material, core size, and excitation level. This allows the reduction of harmonic distortion in filter designs.

When designing a circuit with a ferrite pot core, relative loss factor, inductance, temperature coefficient, and current carrying capacity are important considerations. Attachment 1 to this paper provide additional information about these important concepts.

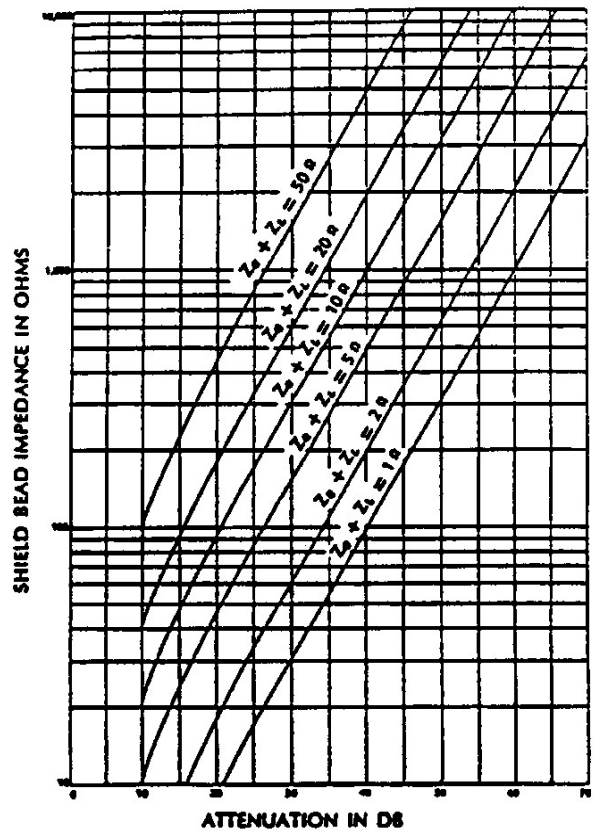

Figure 9-11 Shield Bead Impedances for Several Different Loads

## Conclusions

Ferrite cores and beads offer a compact, low cost, and quickly available means of reducing unwanted noise. As modern equipment operates at higher frequencies and creates more susceptibility problems for other equipment, the use of ferrite material will increasingly become the norm in standard circuit design.

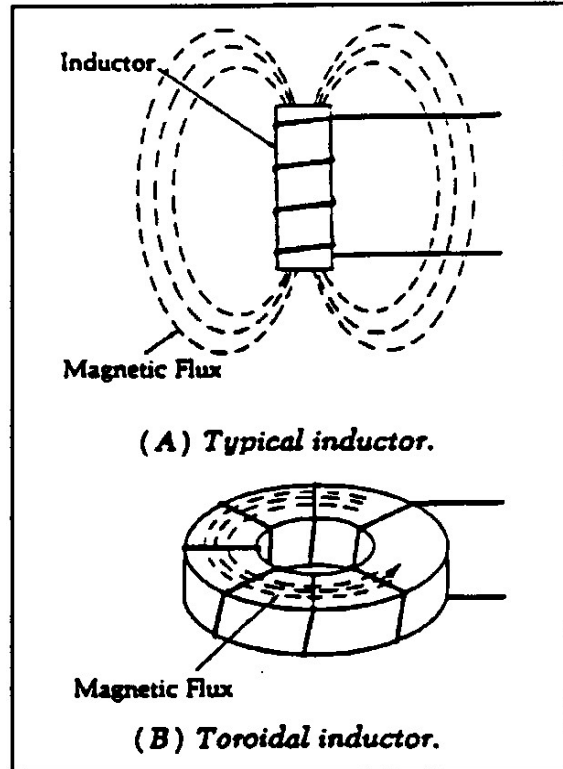

Figure 9-12 Flux Control in a Typical and Toroid Wound Inductor