

Emission Suppression Techniques Using Gaskets

Bruce C. Gabrielson, PhD
Security Engineering Services, Inc.
PO Box 550
Chesapeake Beach, MD 20732

Numerous articles have appeared describing electrical circuit noise suppression techniques to be used in computer applications, but few articles, other than those addressing gaskets, are available describing mechanical "containment" approaches for noise suppression. While most EMI engineers seem to understand the value of providing "good" metal to metal contact at seams, often the need for sealing holes and grounding all non-grounded metal parts is not fully understood. Therefore, a review of these concepts for computer type boxes should prove helpful. This paper is intended to provide basic guidelines as well as specific mechanical type suggestions to reduce noise problems associated with computer designs.

Introduction

State of the art pc's and workstations commonly contain noise generating sources emitted from circuits operating at clock speeds between 20 and 40 MHz. While these computing devices are shielded, in a realistic sense, the direct shielding provided by the box walls is usually of less concern than the noise leakage through box seams, holes, and joints. In addition, these shield discontinuities have more effect on magnetic than on electric field leakage.

Three factors determine the amount of direct radiated leakage through a shield discontinuity.

1. The maximum linear dimension of the opening
2. The wave impedance
3. The frequency of the noise source

Since maximum dimension, not area, determines the amount of leakage in the direct radiated path, the best way to visualize shielding effectiveness of discontinuities is to consider the characteristics of a slot antenna on magnetically induced shield currents.

Slot Antenna Characteristics

Noise fields induce current flow in a shield, and these shield currents then generate additional fields. The new fields that have been reduced somewhat by resistive heating cancel the original field at some regions in space, causing a further reduction in the original field strength. For maximum cancellation to occur, the shield currents must be allowed to flow undisturbed in the manner in which they were initially induced by the incident field. If a shield discontinuity forces the induced currents to flow in a different

path, the shielding effectiveness of the shield is reduced. The further the current is forced to detour from its "natural" path, the greater the decrease in shielding effectiveness.

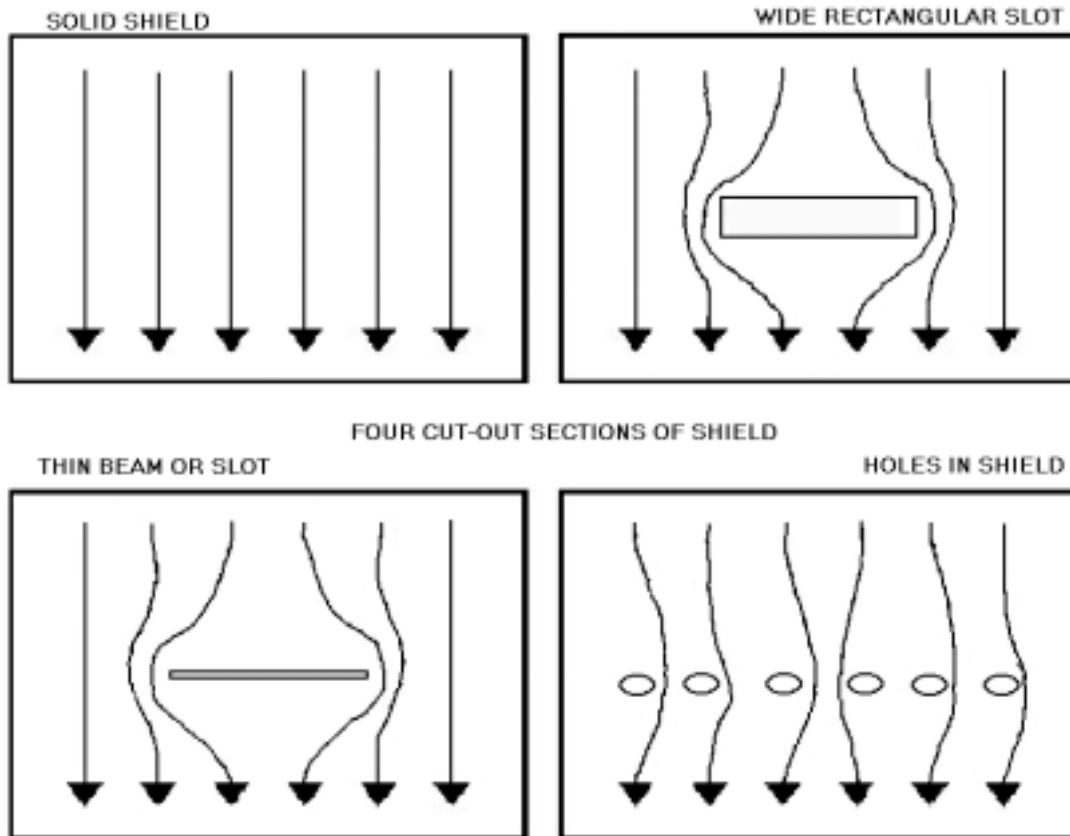

Figure 1 - How Shield Discontinuities Effect Current Flow

Figure 1 shows how current flows in a continuous shield and how discontinuities can affect the currents induced in the shield. Figure 1a shows induced currents in a solid shield with no discontinuity. Figure 1b shows a wide rectangular slot detouring the induced currents, while Figure 1c shows almost the same effect on current flow with a much narrower slot. Figure 1d shows that the group of small holes has a much less current detouring effect than the slots, producing less leakage even though the total area is the same as the slot.

A rectangular slot antenna, even if very narrow such as the cover seam shown in Figure 2, can cause considerable leakage if the slot length is longer than 1/100 wavelength of the radiating source. Even then, if only a 20 MHz source was the concern, a small slot would not be much of a problem if

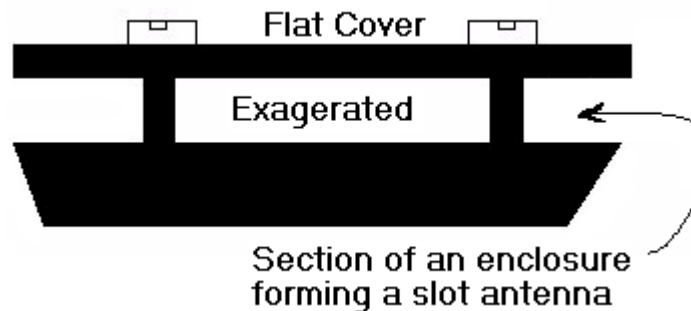

Figure 2 - "Natural" Slot Antenna

oriented for minimum current disturbance. However, the side of a computer or workstation is large, and the clock speed of the computer is only an indicator of the frequency content of the noise since to operate at higher frequencies, internal circuit gates must possess significantly fast rise and fall times. Thus, the source of radiated noise in the 100 Mhz and above range propagates in every direction. Therefore, although the box seams do not appear large, they nearly always offer considerable disturbance to internal induced current flow.

Waveguides and Mechanical Considerations

When a gasketed joint such as shown in Figure 3 exists, the current flow in the shield sees a less abrupt impediment to natural flow than a hole would create, but it is still disturbed to the point that directed fields will be created. A second Figure (4) shows a waveguide condition without a gasket. The figures show a radiating source and current flow through a shield slot. In either case, although the current flow is somewhat disturbed at the joint, the overall impedance of the joint is decreased.

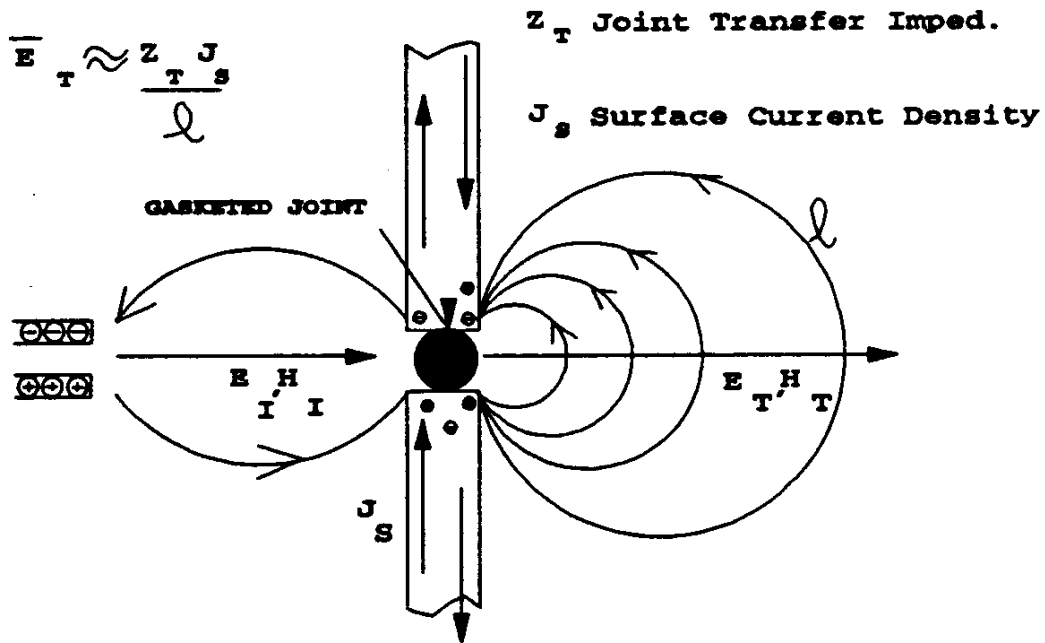

Figure 3 - Gasketed Joint Showing Less Abrupt Impedance

For the waveguide, the high frequency surface currents tend to "jump" the seam boundary rather than be confined to the physical turns and changes in the conductive structure. Therefore, by adding some waveguide characteristics to the seam, internal current will be less disturbed than otherwise would exist, and shielding effectiveness will be greater.

For the gasket filled slot, the gasket provides a conductive seal across the slot, again allowing better natural current flow than would otherwise exist.

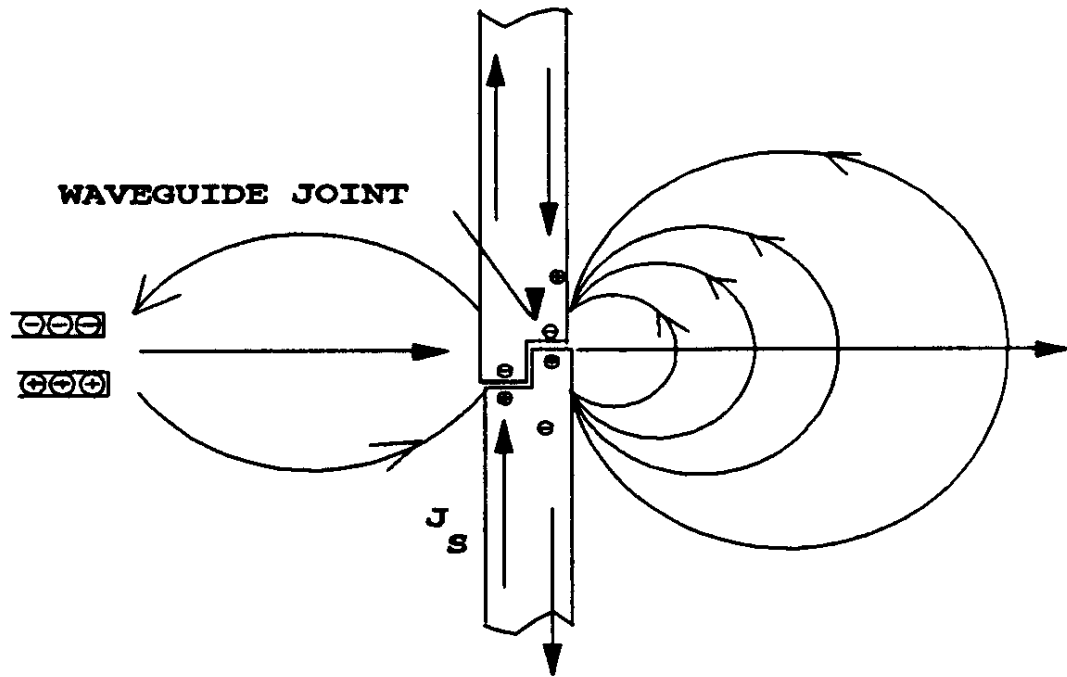

Figure 4 - Waveguide Condition Without Gasket

Conductive Gaskets

Obviously, solid joints provide maximum shielding. Joints with waveguide designs are more desirable than straight through seams, and gasketed joints (for specific applications) are even more desirable. Using rivets or screws to hold a joint together are less effective at sealing a joint, with screws better than rivets. Screws should be spaced as close as practical, with conductive gasket material used to provide more complete electrical continuity across the joint.

For computer and workstation applications, various gasket types and sizes as shown in Figure 5 are available depending on the final application intended for the computer. Tactical computers require greater shielding protection, both environmentally and electromagnetically, than do computers intended for home or office use.

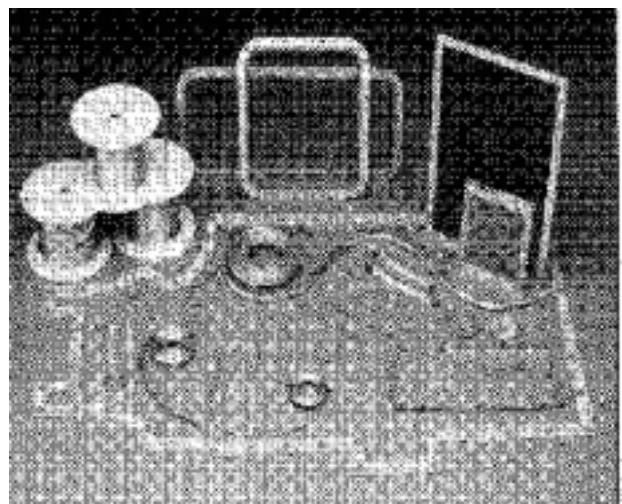

Figure 5 - Typical Gasket Designs

As previously stated, conductive gaskets are used primarily to provide a semi-continuous electrical bond between two metal surfaces along nonuniform seams in enclosures. While

silver filled elastomers are the more common gasket material for military hardened applications, knitted wire mesh, soft preformed metal gaskets, and Beryllium copper spring fingers are also commonly used in less stringent computer applications.

Conductive Elastomers

Filled elastomers usually consist of small conductive carbon or silver beads immersed in a rubber type material. Silver (Ag) is the most popular loading material, providing the highest shielding effectiveness in stringent computer applications. Silver has a low electrical resistance, is a soft metal that can be "crushed" between two harder metals, and suffers much less corrosion than other metals or carbon when encased in rubber, leading to a longer life span and greater shielding effectiveness than alternative techniques.

Conductive elastomers, however, have their own unique problems. According to Benn(1), the concentration of silver filler in the elastomer makes up nearly 70 percent of the gasket by weight. At this high of loading, the elastomer loses much of its physical properties, often resulting in poor tear resistance, and the inability to return to its original form after compression (compression set). Compression set is the permanent reduction in volume of the gasket while under pressure. Compression set usually results in a corresponding loss in shielding effectiveness for the gasket.

The major problem occurs when elastomers are used to provide a continuity bond between different metal surfaces, or between any two metal surfaces and a different fill material. This problem relates to the electro-chemical characteristics of the materials formed by the bond. When Ag and aluminum (Al) are mated together in the presence of moisture, they form a galvanic cell with a galvanic voltage about 0.7 volts. Also, since Ag is more noble than Al, when Al is used with Ag, the Al will corrode. Gasket manufacturers are currently investigating the use of sacrificial materials to inhibit corrosion of case and gasket materials.

Aluminum oxide (Al₂O₃) formed on the Al surface is another problem. Conductive coatings for metal surfaces in these applications have been developed which minimize the corrosion effects by minimizing the formation of Al₂O₃. While the protective finish provided by MIL C 5541, Class 3

Chromate conversion coating minimizes the oxidation process, it also greatly effects the shielding effectiveness of the gasket material(2).

Conductive elastomers are best used in bolt down applications similar to those shown in Figure 6 where they can be replaced after several compressions provided some mechanical offset to reduce closure force on the gasket is also provided. While the rubber material on the outside of the gasket provides significant hermetic sealing, silver filled elastomers should not be used in applications where they provide a seal

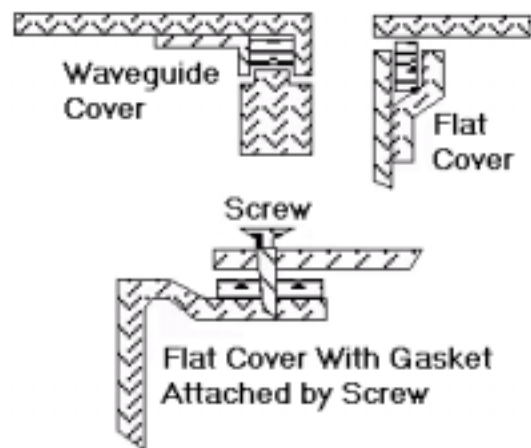

Figure 6 – Gasket Compression Bolting

between aluminum surfaces in contact with a salt water atmosphere. For permanent high closing force mounting, a condition where compression set and high pressure are not a factor, a flat conductive elastomer is well suited.

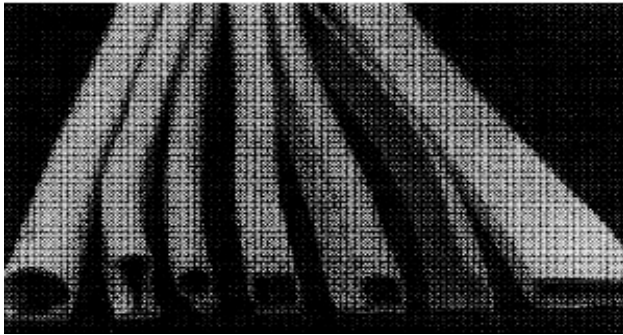

Figure 7 - Pre-formed Elastomer Gasket

A dual elastomer gasket design is available that is intended to provide good mechanical conformance. This gasket, shown in Figure 7, manufactured by Vanguard Products of Danbury, Connecticut, consists of a continuously extruded high-strength nonconductive silicone rubber coated with a thin conductive silver-filled rubber on the outside.

Some major advantages are realized with the extruded approach. First, extrusions are inexpensive to build and can be manufactured very quickly. Major tooling is not a problem. Second, again according to Benn(2), because the silver filler is only present in the outer layer, the silver thickness can be better regulated leading to further reduced manufacturing costs. Finally, the elastic inner core, since it is free of conductive filler material, can maintain its resistance to multiple compressions with corresponding reduced aging.

Foam Gaskets

Nonconductive foam type gaskets covered with metallized fabric provide good compression force and compression-set resistance for relatively lower costs than elastomers, but they also have limited application. Shielding limitations relate to providing no better shielding than that provided by the fabric itself. Also, since the sponge foam usually absorbs moisture, the foam material can deteriorate due to fungus action. A typical mesh covered gasket and a carbon filled gasket, both manufactured by Pawling Corporation, are shown in Figure 8. These gaskets are attached to a metal clip for easy installation.

Metal (Punched) Meshes

Metal Meshes, even soft metal gaskets, have good attenuation properties while lacking in environmental protection. These gaskets are often used in conjunction with an outer rubber gasket to provide a moisture seal.

Soft metal gaskets are pre-shaped and stamped out of a solid sheet to produce sharp edges spaced evenly throughout both sides of the sheet. When compressed, the edges contact the metal enclosure edges causing a very good low impedance bond to be formed. Metal meshes act in a similar manner by providing good metal-to-metal contact between the conductive wires and the enclosure edges.

A problem with all metal mesh or gasket designs is compression force and compression set. Over compressing the gasket results in "flattening" the sharp edges or metal wires

causing loss of the low impedance bond. In addition, compression set is usually permanent once the gasket is set in place.

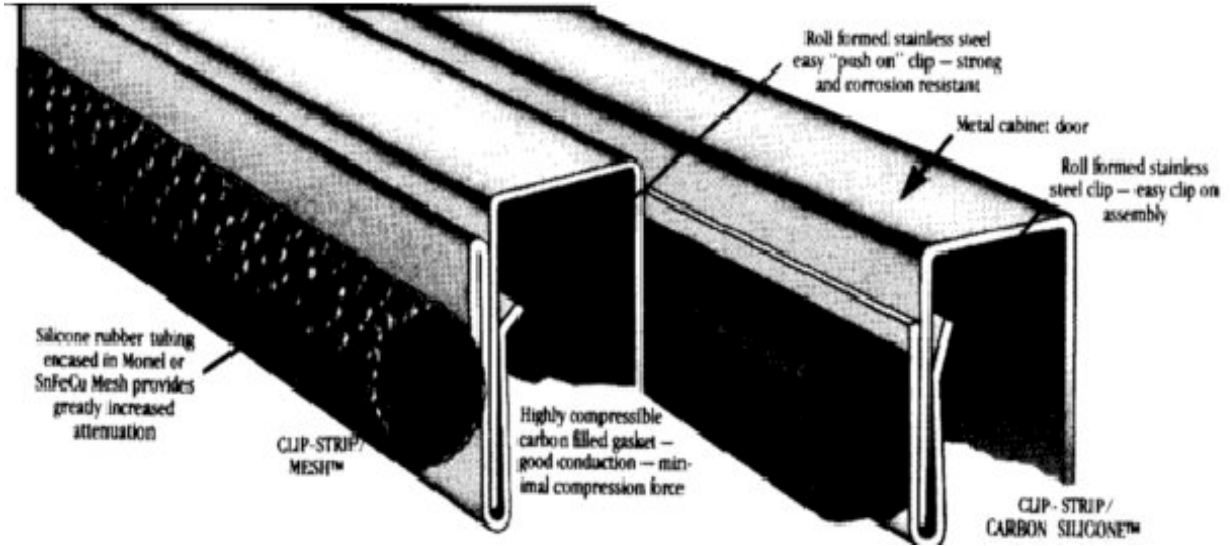

Figure 8 - Metal Braid Covered Foam Gasket

Beryllium Copper Finger-Stock (Springs)

When the gasket will be subjected to multiple compressions, beryllium copper gaskets in the form of small spring fingers or spiral type gaskets like the one shown in Figure 9 are most popular. If high radiated shielding attenuation is necessary, fingerstock is applied as shown for the workstation in Figure 10. Note in Figure 10 that the door is hinged and compressed into the finger stock with a latching mechanism when closed.



Figure 9 - Spiral Type Gasket

A typical use for fingerstock is in the commercial computer application shown in Figure 11. In a straight line they provide less direct shielding effectiveness than other gasket materials, so are usually used with a wave guide slot or wide metal flange.

In commercial computers, as was previously shown, only a few beryllium copper fingers are used, primarily to provide a low impedance ground path between the outer cover and base chassis. Another very popular application for this gasket type is for the connector to shield braid conductive barrier in a compressed ring configuration.

Beryllium copper gaskets are slightly more expensive than other materials, and are subject to corrosion and oxidation when exposed to humidity. Finger-stock has some advantages over other gasket types. It can be repaired when a finger breaks off, and can also be sanded and/or cleaned to return to its original low impedance contact state.

It is important to again note that some mechanical means, such as the waveguide standoff, or a low compression force is necessary to prevent compression set and that the dual elastomer design provides high attenuation with no compression set.

References

1. Benn, Robert C., Dual Elastomer EMI Gasket Concept, ITEM Magazine, 1991.
2. H.W. Denny and K.R. Shouse, EMI Shielding of Conductive Gaskets in Corrosive Environments, IEEE Symposium, Washington D.C., August 1990.

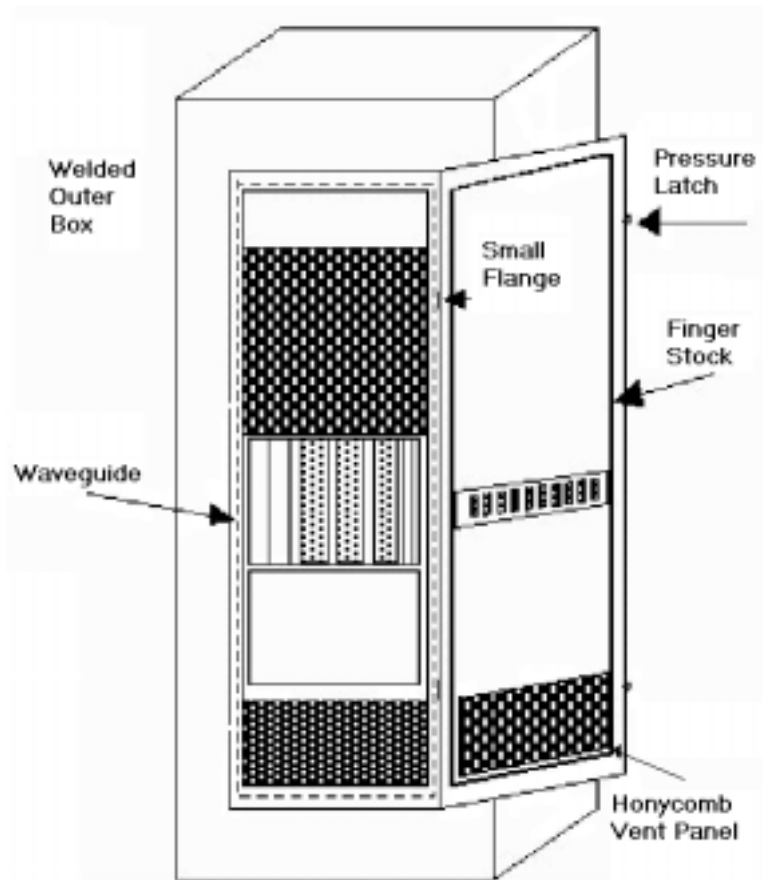
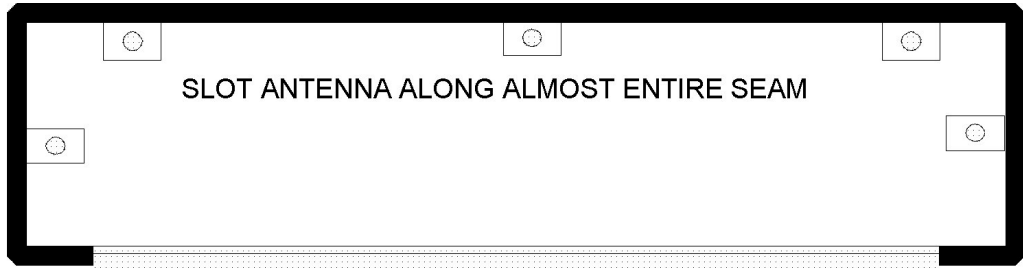

Figure 10 – High Attenuation Application of Fingerstock



BOX VIEWED FROM BACK



BOX VIEWED FROM SIDE
(NORMALLY SUPPLIED WITH PAINT COATING)

COMMON LOCATIONS FOR
ADDED FINGER STOCK

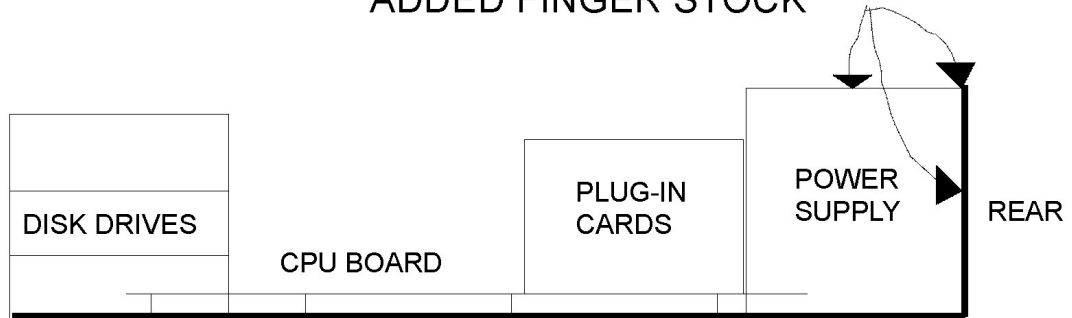

SIDE VIEW OF INTERNAL ASSEMBLY
(DISK DRIVES AND POWER SUPPLY NOT TO SCALE)

Figure 11 - Typical Computer Application of Fingerstock